

(No Model.)

2 Sheets—Sheet 2.

J. O. MESSERLY.
STONE WORKER'S LATHE.

No. 314,462.

Patented Mar. 24, 1885.

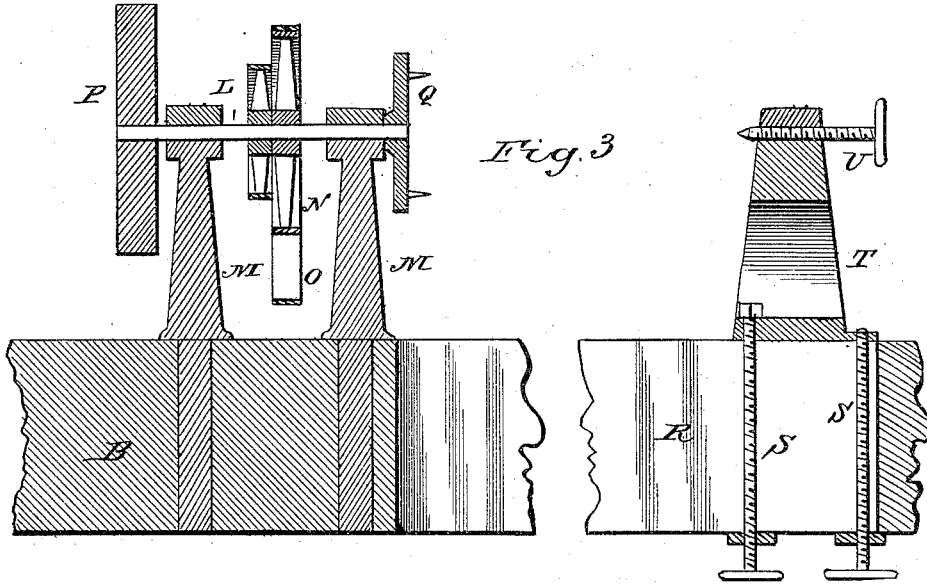

Fig. 3

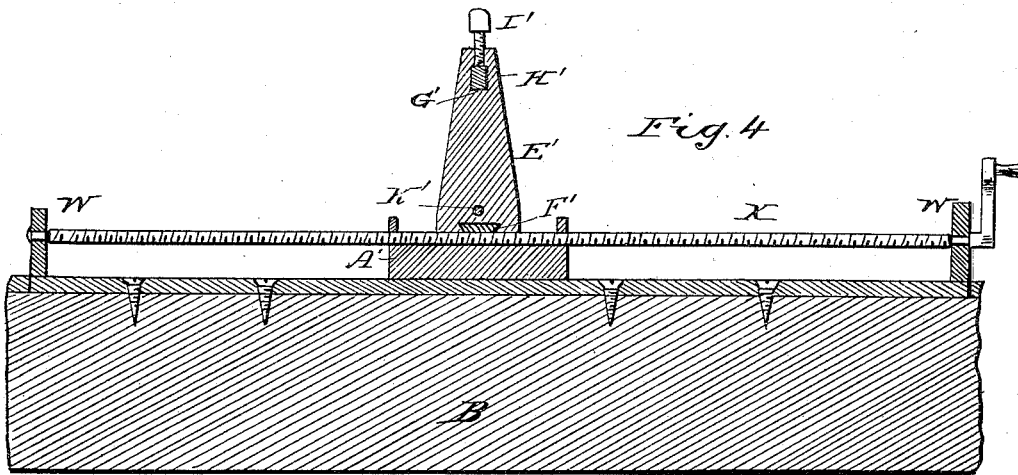

Fig. 4

WITNESSES:

Ad. G. Dieterich
Wm. Bagger

James O. Messerly
INVENTOR.
by: *Louis Bagger & Co.*
ATTORNEYS.

UNITED STATES PATENT OFFICE.

JAMES ORLANDO MESSERLY, OF BALTIMORE, OHIO.

STONE-WORKER'S LATHE.

SPECIFICATION forming part of Letters Patent No. 314,462, dated March 24, 1885.

Application filed December 10, 1884. (No model.)

To all whom it may concern:

Be it known that I, JAMES O. MESSERLY, a citizen of the United States, and a resident of Baltimore, in the county of Fairfield and State of Ohio, have invented certain new and useful Improvements in Stone-Workers' Lathes; and I do hereby declare that the following is a full, clear, and exact description of the invention, which will enable others skilled in the art to which it appertains to make and use the same, reference being had to the accompanying drawings, which form a part of this specification, and in which—

Figure 1 is a perspective view of my improved stone-worker's lathe. Fig. 2 is a transverse vertical sectional view of the same. Fig. 3 is a longitudinal vertical sectional view taken on the line *x x* in Fig. 2, and Fig. 4 is a longitudinal vertical sectional view taken on the line *y y* in Fig. 2.

The same letters refer to the same parts in all the figures.

This invention relates to lathes for turning stone and marble; and it has for its object to provide a simple, convenient, and inexpensive device which may be readily driven by foot-power, thus enabling stone-turning to be done at home by small establishments which cannot afford to have the steam-power lathes now usually employed to do such turning.

With these ends in view the invention consists in the improved construction and combination of the parts composing the said lathe, which will be hereinafter fully described, and particularly pointed out in the claim.

In the drawings hereto annexed, A designates the frame, which consists, mainly, of two parallel longitudinal beams, B B, mounted upon suitable legs or supports, C C, connected by transverse braces D D. The latter are provided with boxes or bearings E E for the operating-shaft F, which latter is provided with a fly-wheel, G, band wheels or pulleys H H, of different diameters, and a crank, I, extending over a considerable portion of the length of the said shaft and connected by a pitman, J, with an adjustable treadle, K, which during operation may be moved by the foot of the operator, who is thereby enabled to change his position, as required, to remain constantly directly in front of his work. The rear frame-beam B is provided at one end

with a spindle, L, journaled in suitable bearings, M M, and having band wheels or pulleys N N of different diameters, one of which may be connected by a belt or band, O, with one of the pulleys upon the operating-shaft. The outer end of the spindle L carries a grindstone P, and its inner end the chuck Q, which in this case may consist, simply, of a wheel or disk having two or more spurs or lugs projecting from its face, substantially as shown in the drawings. The other end of the rear frame-beam B is provided with a vertical slot, R, through which passes the shank or shanks S of the movable spindle, which is mounted in the adjustable bearing T, in which it is adjustable by the hand-wheel U. The lower end of shank S is screw-threaded and provided with thumb nut or wheel V, which may be tightened up against the under side of the beam, so as to secure the bearing T, with the movable spindle, in any position to which it may be adjusted.

The front beam B of the frame is provided with upwardly-extending ears or lugs W W, affording bearings for the ends of a screw-threaded rod, X, one end of which is provided with a crank or handle, Y, by means of which it may be conveniently turned. The ears or lugs W W are formed at the ends of a plate, Z, suitably secured to the beam B, and having dovetailed edges, so as to retain the longitudinally-sliding tool-carriage A', which latter consists of a block or plate having downwardly-extending flanges B', fitting between the beams B B and against the front side of the front beam, and provided with upwardly-extending ears or lugs C', having screw-threaded perforations to receive the rod X, by revolving which the tool-carriage may be moved longitudinally upon the frame of the machine, the flanges bearing against the inner sides of the beams bracing the tool-carriage, upon which a considerable strain is exerted during operation.

The upper side of the plate or base A' of the tool-carriage is provided with a transverse dovetailed strip, D', on which slides the tool-holder E', which consists of a suitably-shaped block, the under side of which is provided with a dovetailed groove, F', and the upper end of which is provided with a mortise, G', adapted to receive the shank of the tool H',

which is retained in position by means of a set-screw, I'. The ends of the strip D' are provided with upwardly-extending ears or lugs J', forming bearings for the ends of a screw-threaded rod, K', the front end of which is provided with a crank or handle, L', by means of which it may be operated, and which passes through a screw-threaded perforation in the lower part of the tool-holder, which thus, by turning the said screw-threaded rod, may be moved transversely to the frame of the machine. The rear frame-beam is provided near its ends with upwardly-extending curved brackets M' M', connected by a rod, N', which serves to support a water-can, from which water is allowed to escape upon the work, for the purpose of carrying off the dust and preventing the tools from heating. It is obvious that the said water-can may be slid or removed from place to place upon the supporting-rod as the work progresses.

From the foregoing description, taken in connection with the drawings hereto annexed, the operation and advantages of this invention will be readily understood. The construction is simple, and the machine may be operated easily and effectually by foot-power, as described.

It is obvious that changes may be made in

the construction of the details of this device, and I would therefore have it understood that I do not limit myself to the precise construction herein shown, but reserve to myself the right to all such modifications as may be resorted to without departing from the spirit of my invention.

Having thus described my invention, I claim and desire to secure by Letters Patent of the United States—

In a stone-worker's lathe, the combination of the parallel beams B B, the spindles mounted upon the rear beam, the strip Z, having dovetailed edges, the tool-carrier having a dovetailed groove fitting upon the strip, and having the downwardly-projecting flanges B', bearing against the inner sides of the beams and against the outer side of the front beam, and means, substantially as set forth, for sliding the tool-carriage, as and for the purpose shown and set forth.

In testimony that I claim the foregoing as my own I have hereunto affixed my signature in presence of two witnesses.

JAMES ORLANDO MESSERLY.

Witnesses:

SAMUEL S. WEIST,
BENJAMIN WEIST.